

LEGEND
 PROPERTY LINE
 EXISTING CONTOUR
 EXISTING TREE LINE
 EXISTING WIRE FENCE

PLAN VIEW
 SCALE: 1" = 40'
 GRAPHIC SCALE

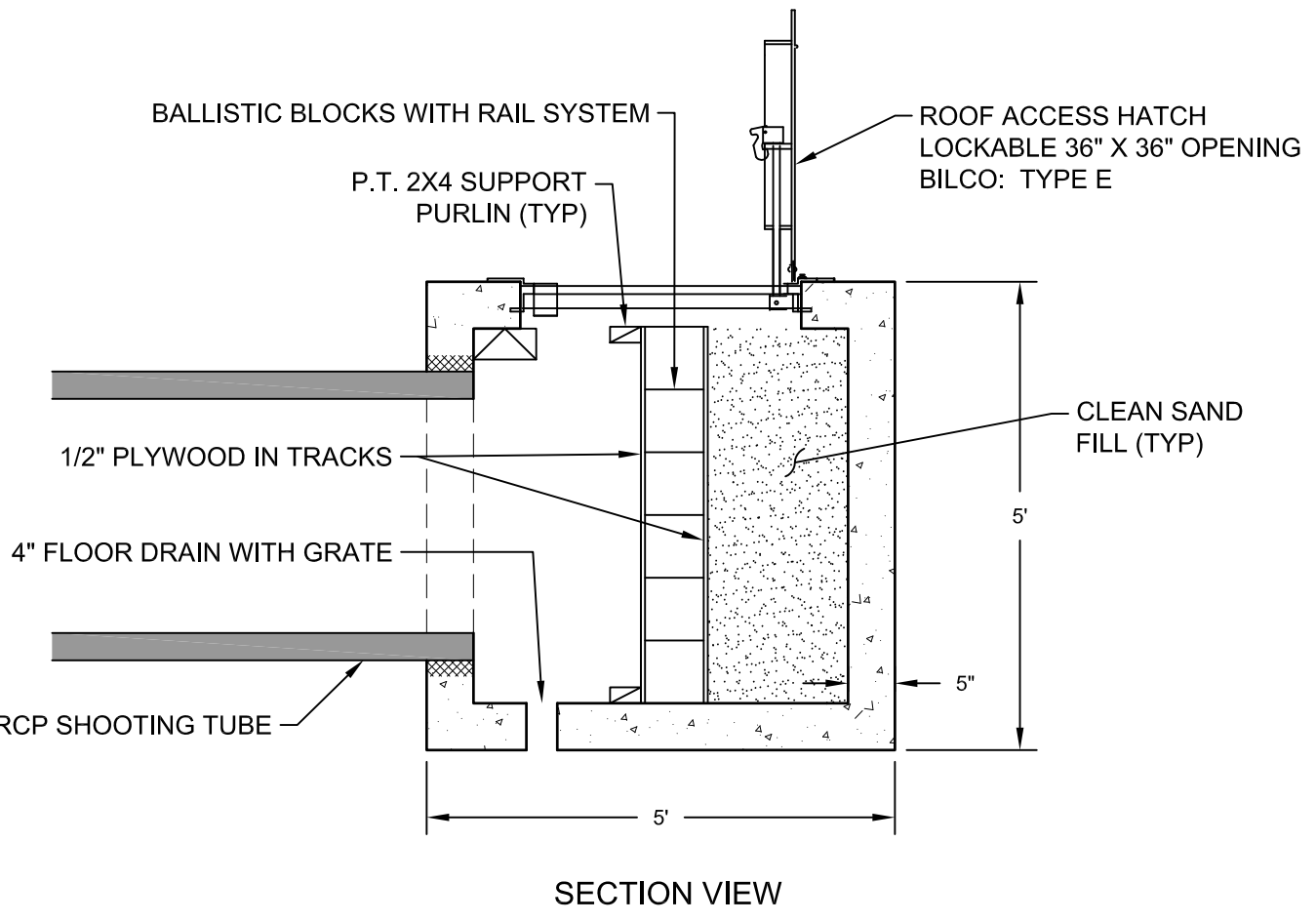

SECTION VIEW

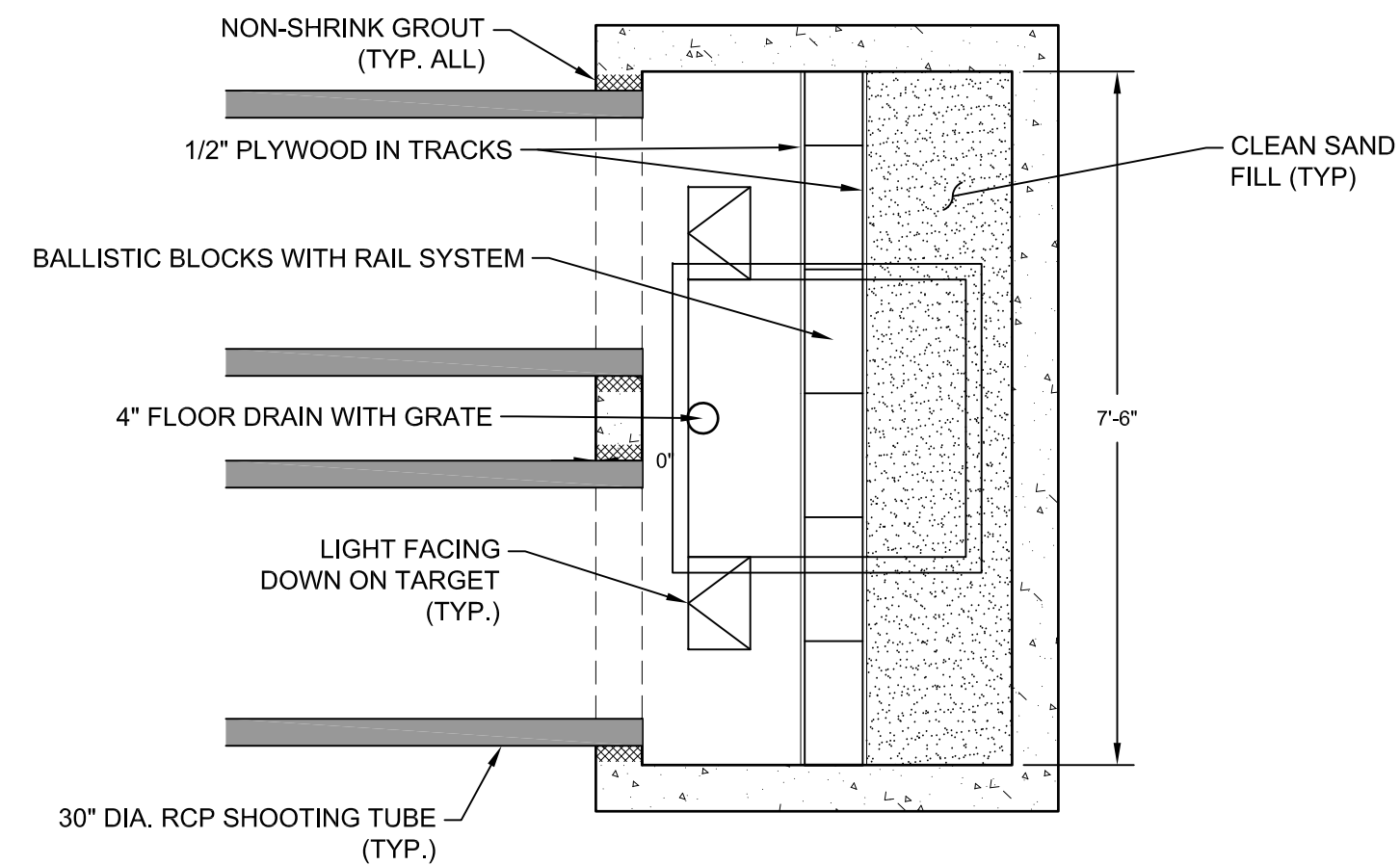

PLAN VIEW

PRECAST CONCRETE BULLET STOP STRUCTURE DETAIL

- NOTES:
 1. CONCRETE STRUCTURE TO BE NEW AND WATERTIGHT.
 2. DIMENSIONS AND CONFIGURATION MAY VARY DEPENDING UPON MANUFACTURER.
 3. ALL PIPE PENETRATIONS TO USE 4" WATERTIGHT HDPE PIPE SEALS.
 4. BUTYL RUBBER SEALANT AT ALL JOINTS.
 5. MIN. CONCRETE STRENGTH - 4000 PSI AT 28 DAYS.
 6. MIN. STEEL REINFORCEMENT: #4 REBAR, 6" X 6" X 10ga WWM, (SIZED BY MANUFACTURER)

SCALE: 1" = 2'

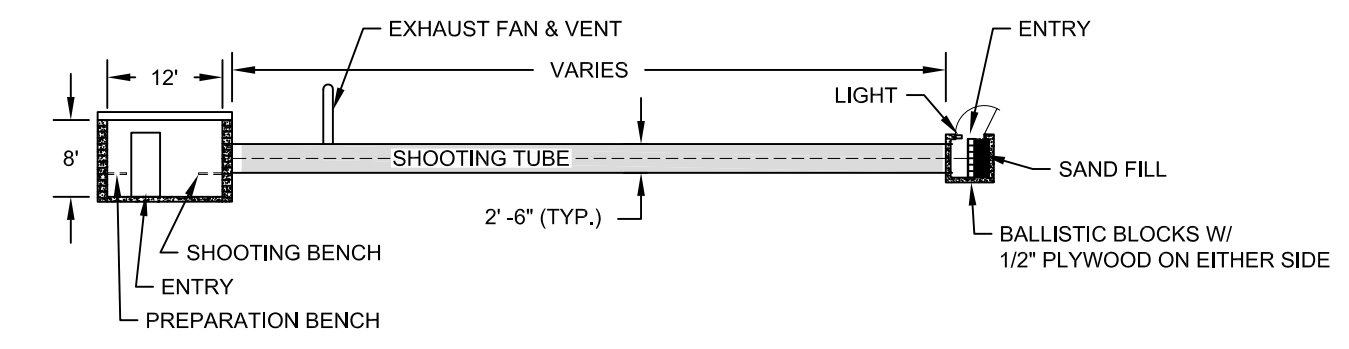

LONGITUDINAL SECTION

SCALE: 1" = 20'

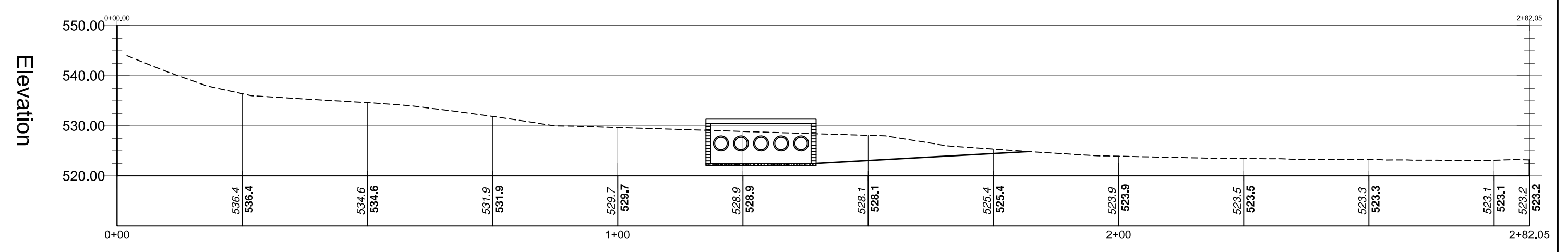

CROSS-SECTION A-A

SCALE: 1" = 20' HORIZ.
 1" = 10' VERT.

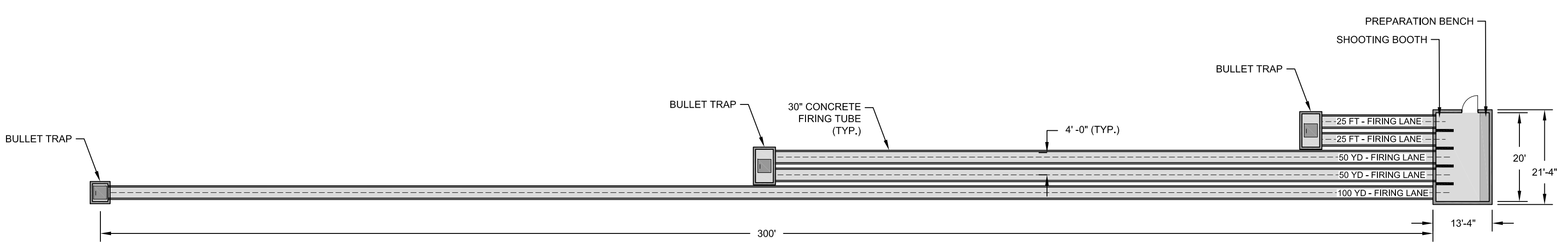

FIRING RANGE LAYOUT DETAIL

SCALE: 1" = 20'

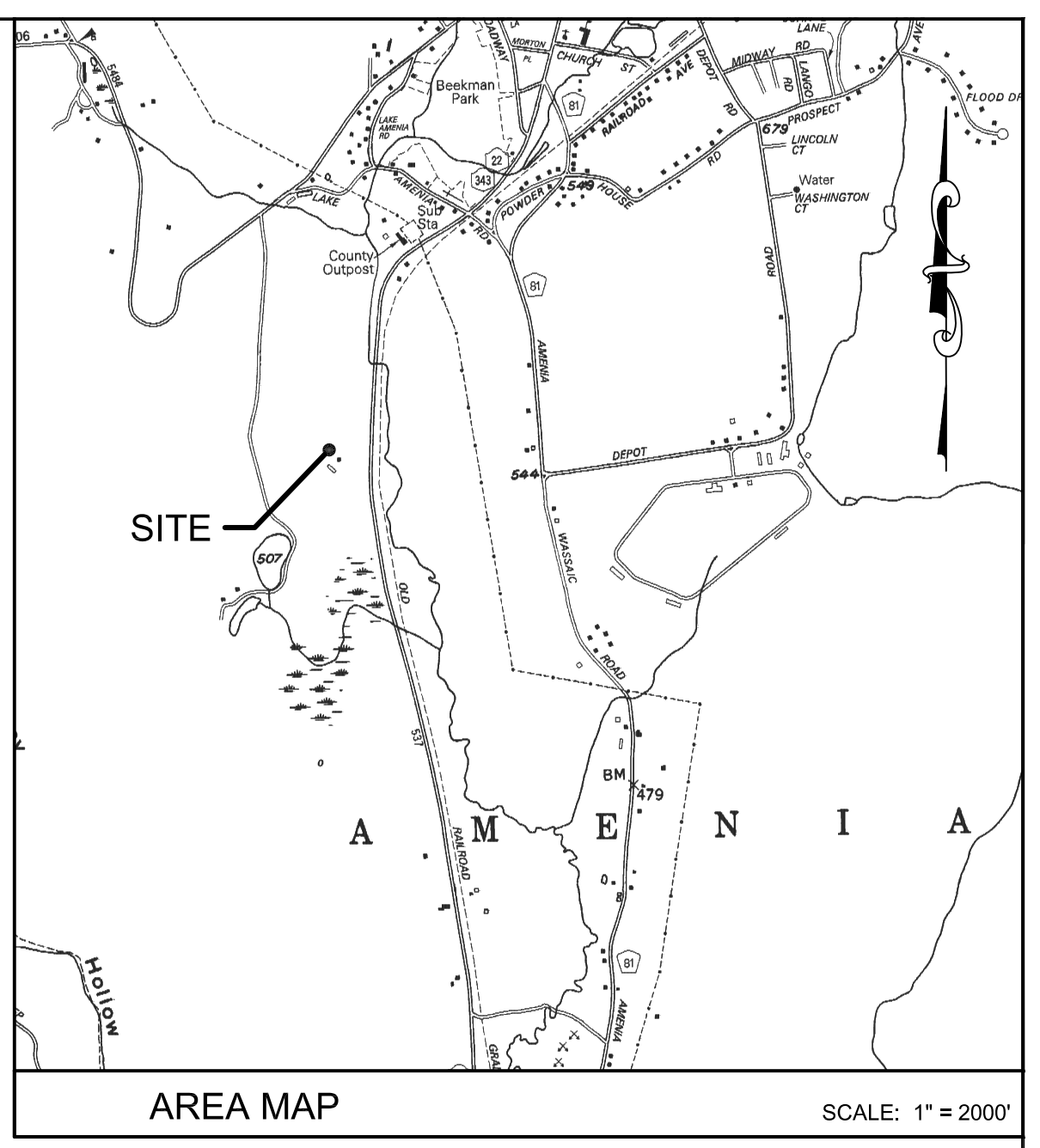

AREA MAP

SCALE: 1" = 2000'

SITE DATA

ZONING DISTRICT: RA "RURAL AGRICULTURE"
 SCO "STREAM CORRIDOR OVERLAY"
 LOT SIZE: ±6.4 ACRES
 TAX GRID No.: 132000-7066-00-854868
 PROPERTY ADDRESS: 4623 ROUTE 22
 AMENIA, NY 12501
 PROPERTY OWNER: AMENIA FISH & GAME
 ADDRESS: P.O. BOX 149
 AMENIA, NY 12501

BULK REGULATIONS

PROVISION	REQUIRED	PROPOSED
MIN. LOT AREA (ACRE)	10	6.4
MAX. IMPERMEABLE SURFACE COVERAGE (%)	10%	5.6%
MAX. BUILDING HEIGHT (FT)	35	10
MAX. BUILDING FOOTPRINT (SF)	6,000	308
MIN. ROAD FRONTAGE (FT)	250 (Town Road)	-
	300 (State Road)	367 (NYS Rte. 22)
MIN. FRONT YARD SETBACK (FT)	40 (Town Road)	-
	60 (State Road)	315 (NYS Rte. 22)
MIN. REAR YARD SETBACK (FT)	50	116
MIN. SIDE YARD SETBACK (FT)	30	30.5

MINIMIZATION OF DISTURBED AREA:
 TOTAL DISTURBED AREA OF THE SITE AS SHOWN ON THIS PLAN SHALL NOT EXCEED 5,000 SF.

DATE	REVISION

ENGINEERING, DESIGN, & PLANS PREPARED BY:
RENNIA ENGINEERING DESIGN, PLLC
 CIVIL & ENVIRONMENTAL ENGINEERING
 6 Dover Village Plaza, Suite 5, P.O. Box 400, Dover Plains, NY 12522
 Tel: (845) 877-0555 Fax: (845) 877-0556
 Copyright 2008, All Rights Reserved
 IT IS A VIOLATION OF NEW YORK STATE EDUCATION LAW FOR ANY PERSON TO ALTER THESE PLANS, SPECIFICATIONS OR REPORTS IN ANY WAY, UNLESS ACTING UNDER THE DIRECTION OF A LICENSED PROFESSIONAL ENGINEER.

AMENIA FISH & GAME					
TOWN OF AMENIA			DUTCHESS COUNTY, NY		
UNDERGROUND FIRING RANGE					
DATE	SCALE	DESIGNED BY	DRAWN BY	CHECKED BY	JOB NO. SHEET NO.
12/22/14	AS NOTED	RED	RED	RAR	#14-021 1 of 1